

WEST COUNTY AGENCY



A Joint Powers Agency of West County Wastewater District
and City of Richmond Municipal Sewer District

BOARD MEETING AGENDA Thursday, June 15, 2017, 9:00 a.m.

Meeting Location: 2910 Hilltop Drive, Richmond, CA 94806

CHAIR: Leonard McNeil VICE-CHAIR: Eduardo Martinez

DIRECTORS: Jovanka Beckles (COR) - Audrey Comeaux (WCWD)

ALTERNATES: Sherry Stanley (WCWD), Jael Myrick (COR)

1. ROLL CALL

PLEDGE OF ALLEGIANCE

2. SPECIAL ORDER OF THE DAY

- a. Adjourn in Recognition of June 23, 2017 as United Nations Public Service Day*
- b. Reorganization of the Agency Board of Directors (*appointment of WCA Chair and Vice Chair for Fiscal Year 2018*) (**Attachment**)
- c. Presentation of Resolutions Recognizing and Commending Nathaniel R. Bates and Michael T. Caine on their Years of Service with West County Agency

3. PUBLIC COMMENTS

4. MINUTES

- a. March 16, 2017 Board Meeting (*approve and accept*) (**Attachment**)

5. RESOLUTIONS (*the Board will discuss, seek public input and possibly take action to approve the following items*)

6. UNFINISHED BUSINESS (*the Board will discuss, seek public input and possibly take action to approve the following items*)

7. NEW BUSINESS (*the Board will discuss, seek public input and possibly take action to approve the following items*)

- a. San Francisco Bay Regional Water Quality Control Board Monthly NPDES Compliance Reports through the month of April 2017 (*receive and accept*) (**Attachment**)
- b. Underwater ATON Marker Inspection - April 5, 2017 (*receive and accept*) (**Attachment**)

8. **BOARD/STAFF REPORTS** (*receive and accept*)

- a. **Report from Board** on recent conferences, seminars and issues pertaining to the overall operation of the West County Agency
- b. **Report from Manager and Staff** on recent conferences, seminars and issues pertaining to the overall operation of the West County Agency
- c. Report on Staff Meeting Regarding the Agreement between the City of Richmond and West County Wastewater District on the Sodium Bisulfite Project at Richmond's Plant Facilities
- d. Report on Rockslide Situation at the back of Richmond's Plant Facilities where both agencies effluents meet that could affect the co-effluent structure
- e. Receive Board Attorney Comments/Communications - April 1, May 1 and June 1, 2017 Statements of Services (*receive and accept*) (**Attachment**)

9. **FINANCES**

- a. Budget to Actuals Report through May 2017 and Check Register for March, April and May 2017 (*receive and accept*) (**Attachment**)
- b. Adopt West County Agency Fiscal Year 2018 Proposed Budget (*motion and vote to approve*) (**Attachment**)

10. **UPCOMING MEETING AGENDA ITEMS** (for discussion at a future meeting)

- Next Meeting Date - Thursday, October 12, 2017

11. **CLOSED SESSION**

12. **ADJOURNMENT**

Adjourn in Recognition of June 23, 2017 as United Nations Public Service Day*

**The United Nations' Public Service Day is held on June 23 each year. It recognizes that democracy and successful governance are built on the foundation of a competent civil service. The day aims to celebrate the value and virtue of service to the community.*

INFORMATION FOR THE PUBLIC

Persons with disabilities who require auxiliary aids or services in attending or participating in this meeting should call the Administration Supervisor at (510) 222-6700. We will need FIVE (5) WORKING DAYS BEFORE ANY FUTURE MEETINGS to make any necessary accommodations.

Anyone wishing to address the Board of Directors should complete a speaker's card and submit it to the Administration Supervisor. In addressing the Board, speakers should step to the podium and state their names and addresses for the record. The Board Chair may direct questions to any member of the audience as appropriate at any time during the meeting.

1. ADDRESSING THE BOARD ON AN ITEM ON THE AGENDA

*Persons wishing to speak on **PUBLIC HEARINGS** and **OTHER MATTERS** listed on the agenda will be heard when the President calls for comments from the audience, except on public hearing items previously heard and closed to public comment. A maximum of 3 minutes will be allowed for those who wish to address the Board. After the public has commented, the item is closed to further public comment and brought to the Board for discussion and action. There is no further comment permitted from the audience unless invited by the Board.*

2. ADDRESSING THE BOARD ON AN ITEM NOT ON THE AGENDA

*In accordance with state law, the Board is prohibited from discussing items not calendared on the agenda. For that reason, members of the public wishing to discuss or present a matter to the Board other than a matter which is on this agenda are requested to present the matter in writing to the Secretary to the Board at least one week prior to a regularly scheduled Board meeting date. If you are unable to do this, you may make an announcement to the Board of your concern under **PUBLIC COMMENTS**. Matters brought up which are not on the agenda may be referred to staff for action or calendared on a future agenda.*

WEST COUNTY AGENCY



A Joint Powers Agency of West County Wastewater District
and City of Richmond Municipal Sewer District

TO: Honorable West County Agency Board of Directors
DATE: June 15, 2017
REPORT BY: Ed McCormick, Interim Agency Manager *LMZ for EHS*
SUBMITTED BY: Maria L. Sena, WCWD Administration Supervisor
SUBJECT: Reorganization of the Agency Board of Directors

RECOMMENDATION

It is requested that Chairman Leonard McNeil open nominations for Chair and Vice Chair for the ensuing Fiscal Year 2018. The Board should then vote on the new officers.

FISCAL IMPACT

There is no cost from the recommended action.

BACKGROUND AND DISCUSSION

Pursuant to the Joint Exercise of Powers Agreement, the Chair and Vice Chair shall hold office for one year as of the date of appointment to the following June 30. Upon the election by the Board, the newly appointed Chair and Vice Chair will assume their position effective July 1, 2017.

Attached for the Board's information is a list of the succession of the Agency Officers since the year 2000.

Staff will be available to answer any questions or provide further information at the request of the Board.

SUPPORTING DOCUMENTS

Attachment A: Succession of West County Agency Officers

BOARD MEMBERS: Jovanka Beckles - Audrey Comeaux - Eduardo Martinez - Leonard McNeil
ALTERNATE BOARD MEMBER: Jael Myrick, City of Richmond - Sherry Stanley, WCWD
BOARD ATTORNEY: Alfred Cabral INTERIM AGENCY MANAGER: Ed McCormick



Succession of West County Agency Officers

<u>TERM</u>	<u>CHAIR</u>	<u>VICE CHAIR</u>
2000-01	Thomas Butt	Leonard Battaglia
2001-02	Leonard Battaglia	Mindell Penn
2002-03	Mindell Penn (6/02-1/03) William Oliver (2/03-6/03)	William Oliver Nathaniel Bates
2003-04	Nathaniel Bates	Leonard Battaglia
2004-05	Leonard Battaglia	Richard Griffin
2005-06	Richard Griffin	William Oliver
2006-07	William Oliver (6/06-1/07) Alfred Granzella (2/07-/07)	Nathaniel Bates
2007-08	Nathaniel Bates	Leonard Battaglia
2008-09	Leonard Battaglia (7/08-12/08) Maria Viramontes (1/09-6/09)	Maria Viramontes (7/08-12/08) Alfred Granzella (1/09-6/09)
2009-10	Alfred Granzella (7/09-12/09) Nathaniel Bates (1/10-6/10)	Nathaniel Bates (7/09-12/09) Paul C. Soltow, Jr. (1/10-6/10)
2010-11	Paul C. Soltow, Jr. (7/10-12/10) Nathaniel Bates (1/11-6/11)	Maria Viramontes (7/10-12/10) Alfred Granzella (1/11-6/11)
2011-12	Alfred Granzella	Nathaniel Bates
2012-13	Nathaniel Bates	Leonard Battaglia
2013-14	Courtland "Corky" Boozé	Alfred Granzella
2014-15	Alfred Granzella	Nathaniel Bates
2015-16	Nathaniel Bates	Michael Caine
2016-17	Michael Caine (7/16 - 12/16) Leonard McNeil (3/16 - 6/17)	Eduardo Martinez



The meeting of the West County Agency Board of Directors was held in the West County Wastewater District Alfred M. Granzella Board Room, 2910 Hilltop Drive, Richmond, California.

The meeting was called to order at 9:05 a.m. by Chair Pro Tem Eduardo Martinez

1. ROLL CALL

Roll call was taken and the following members were present:

Eduardo Martinez	Chair Pro Tem
Leonard R. McNeil	Director
Audrey Comeaux.....	Director
Alfred Cabral	Agency Board Attorney
Maria L. Sena.....	Administration Supervisor /Secretary to the Board

Director Beckles was absent

Also present were Veolia Water Project Manager Aaron Winer, City of Richmond Wastewater/Stormwater Manager Ryan Smith, West County Wastewater District Business Services Manager Lisa Malek-Zadeh, Engineering Services Manager Ken Cook, Finance Supervisor Dean Prater, former West County Agency Director Alfred M. Granzella, and Larry Walker Associates representative Denise H. Connors.

2. SPECIAL ORDER OF THE DAY

a. Adjourn in Recognition

Today's meeting will adjourn in recognition of March 22, 2017, as World Day for Water.

b. Introduction of new City of Richmond and West County Wastewater District's Representatives to the West County Agency Board

West County Wastewater District (WCWD) Vice President Audrey Comeaux representing WCWD was introduced and welcomed by Chair Pro Tem Martinez. Council Member Jovanka Beckles representing the City of Richmond was not present.

c. Selection of a Chairperson to Replace Outgoing West County Wastewater District Representative

A nomination was made by Director Comeaux, seconded by Chair Pro Tem Martinez and approved unanimously to select Director McNeil as the replacement of the outgoing West County Wastewater District Representative as Chair on the West County Agency Board and serve the remainder of the term of office.

Chair Pro Tem Martinez returned to his position of Vice Chair and passed the gavel over to newly appointed Chair McNeil to continue the meeting.

Chair McNeil introduced Sherry Stanley West County Wastewater District's new alternate representative to the West County Agency.

d. Presentation of Resolutions Recognizing and Commending Nathaniel R. Bates, Michael T. Caine and Alfred M. Granzella on their Years of Service with West County Agency

Nathaniel R. Bates and Michael T. Caine were not able to attend today's meeting. The Board will postpone the presentation of their resolutions for the next Agency Board meeting.

The Board presented resolution number 16-007 to Alfred M. Granzella recognizing and commending him on his retirement from the West County Wastewater District and the West County Agency Board of Directors.

Former Director Alfred M. Granzella described his history with the West County Wastewater District and the West County Agency, and thanked the Board for recognizing and commending him on his retirement.

Mr. Everett Jenkins, City of Richmond Senior Assistant City Attorney, and Vice Chair Martinez thanked Alfred M. Granzella for his service, guidance, and dedication to the wastewater industry.

e. Presentation on the West County Agency NPDES Permits and Larry Walker Associates Assistance by Denise H. Conners.

Denise Conners, representative of Larry Walker Associates, gave a PowerPoint presentation that giving an overview of the National Pollution Discharge Elimination Systems (NPDES) permit operations and assistance provided to the West County Agency, West County Wastewater District and City of Richmond, by Larry Walker Associates.

3. PUBLIC COMMENTS

None.

4. MINUTES

Minutes of the December 1, 2016, Board meeting were approved and accepted on a motion by Vice Chair Martinez, seconded by Director Comeaux by the following unanimous vote:

Ayes: Martinez
Noes: None
Abstain: Comeaux, McNeil
Absent: Beckles

5. RESOLUTIONS

None.

6. UNFINISHED BUSINESS

a. San Francisco Bay Regional Water Quality Control Board Monthly Reports, October 2016, November 2016, December 2016 and January 2017

The San Francisco Bay Regional Water Quality Control Board monthly reports for October 2016, November 2016, December 2016 and January 2017 were received and accepted.

Veolia Water Project Manager Aaron Winer addressed the Board to report that there were no NPDES permit violations for the months of October 2016 through December 2016, or in January 2017, even though we experienced a lot of rain. He also described the blending, treatment, and discharge process of the City of Richmond Plant and described some incidents that occurred in February, during high water flow periods, that caused some possible minimal Chlorine residual violations to the NPDES permit.

b. West County Agency Annual Mandatory Minimum Penalties Self-Monitoring Report for the year 2016

The West County Agency Annual Mandatory Minimum Penalties Self-Monitoring Report for the year 2016 was received and accepted.

7. NEW BUSINESS

a. Marine Outfall Quarterly ATON Buoys Inspection - December 22, 2016

The Marine Outfall quarterly ATON buoys inspection report dated December 22, 2016 was received and accepted.

8. BOARD/STAFF REPORTS

a. Report from Board

Vice Chair Martinez described his and City of Richmond's Wastewater/Stormwater Manager Ryan Smith's attendance at the California Association of Sanitation Agencies Conference in Palm Springs in January 2017. He also gave a synopsis of a Groundwater Conference he recently attended in Fresno, California.

b. Report from Manager and Staff

None.

c. Receive Board Attorney Comments/Communications - December 1, 2016, and January 1, February 1 and March 1, 2017 Statements of Services

Board Attorney Cabral informed the Board that there were no recent legislative/legal issues that could affect the Agency at this time. His invoices for the months of November 2016 through February 2017 were received and accepted.

d. Report on the City of Richmond Municipal Sewer District

City of Richmond Wastewater/Stormwater Manager Ryan Smith informed the Board of the following items:

- It could be another year before City of Richmond receives information regarding the funding from the State Revolving Fund (SRF) program application they submitted. The SRF program currently does not have enough funds available for all the applications they have received.
- The City of Richmond is looking at selling bonds to fund some of the immediate critical project needs for their Capital Improvement Program.
- The City of Richmond has met all the obligations of the agreement with Baykeeper's except for the number of Sanitary Sewer Overflows per year. They are currently discussing an extension of the settlement agreement for an additional five years.

- The City of Richmond and West County Wastewater District last had a financial true-up meeting in the year 2009. Staffs of both agencies are currently coordinating financial meetings on an annual basis.
- The City of Richmond will be meeting with West County Wastewater District staff regarding a Sodium Bisulfite project upcoming at the Richmond Plant facilities.
- There is a possible rockslide situation at the back of Richmond's Plant facilities, where both agencies effluents meet, that could affect the co-effluent structure. Staff from both agencies will be meeting to make a plan to protect the effluent structure.

9. FINANCES

a. Receive and File the Audited Financial Statements for Fiscal Year Ending June 30, 2016

The audited financial statements for fiscal year ending June 30, 2016 were reviewed, received, and accepted.

b. Budget to Actuals Report for Fiscal Year 2017 through February 2017 and Check Register for November 2016, December 2016, January 2017, and February 2017

The budget to actuals report for fiscal year 2017 through February 2017 was reviewed, received and accepted. There was some discussion on the check register payment numbered 7359. The check register for November 2016 through February 2017 in the total amount of \$192,693.03 was reviewed, received and accepted.

10. UPCOMING MEETING AGENDA ITEMS

- The next regular West County Agency Board meeting will be held on Thursday, June 15, 2017.
- A progress report on the status of possible rock slide situation at the Richmond Plant.

11. CLOSED SESSION

None.

12. ADJOURNMENT

The meeting adjourned at 10:17 a.m., in recognition of March 22, 2017, as World Day for Water.

Return to Agenda

CHAIR

WEST COUNTY AGENCY



A Joint Powers Agency of West County Wastewater District
and City of Richmond Municipal Sewer District

TO: Honorable Board of Directors
West County Agency

DATE: June 15, 2017

REPORT BY: Ed McCormick, Interim General Manager *LMZ for EHS*

SUBMITTED BY: Maria L. Sena, WCWD Administration Supervisor

SUBJECT: Monthly National Pollution Discharge Elimination System (NPDES) Permit Compliance Reports through the Month of April 2017

RECOMMENDATION

This is an informational item only.

FISCAL IMPACT

There is no fiscal impact from this report.

BACKGROUND AND DISCUSSION

Attached are the letters to the San Francisco Bay Regional Water Quality Control Board (SFBRWQCB) regarding the West County Wastewater District (WCWD) and the City of Richmond (Richmond) Treatment Plants compliance with effluent NPDES permit limits for the months of January, February, March and April 2017.

The Richmond Treatment Plant experienced wet weather blending events and equipment malfunctions which were reported for this period. In January 2017 West County Wastewater District Plant experienced basins overflow to Wildcat Marsh creek due to unprecedented rainfall. See attached letters for detailed information.

There were no NPDES permit effluent quality exceedances reported for this period.

Also included are the amended letters for the months of October and December 2016 which were required to be resubmitted because the electronic self-monitoring report (eSMR) upload did not completely upload all the influent results for INF-003.

BOARD MEMBERS: Jovanka Beckles - Audrey Comeaux - Eduardo Martinez - Leonard McNeil
ALTERNATE BOARD MEMBER: Jael Myrick, City of Richmond - Sherry Stanley, WCWD
BOARD ATTORNEY: Alfred Cabral **INTERIM AGENCY MANAGER:** Ed McCormick

Richmond and WCWD Staff will be available to answer any questions the Board may have.

SUPPORTING DOCUMENTS

- Attachment A: SFBRWQCB Letter dated February 28, 2017
- Attachment B: SFBRWQCB Letter dated March 29, 2017
- Attachment C: SFBRWQCB Letter dated April 22, 2017
- Attachment D: SFBRWQCB Letter dated May 30, 2017
- Attachment E: SFBRWQCB October 2016 Amend Letter dated March 31, 2017
- Attachment F: SFBRWQCB December 2016 Amend Letter dated March 31, 2017

WEST COUNTY AGENCY



A Joint Powers Agency of West County Wastewater District
and City of Richmond Municipal Sewer District

February 28, 2017

Bruce Wolfe, Executive Officer
San Francisco Bay Regional Water Quality Control Board
1515 Clay Street, Suite 1400
Oakland, California 94612

RE: File No. 2213.1037 (RMD)tmb

Dear Mr. Wolfe,

Enclosed is the January 2017 Monthly Report.

There were four blending events at the Richmond WPCP in January covering the following time periods:

1. 1/8/17 from 0410 hours through 1/11/17 ending at 1940 hours
2. 1/12/17 from 0134 hours through 1/13/17 ending at 0558 hours
3. 1/18/17 from 2145 hours through 1/19/17 ending at 2200 hours
4. 1/20/17 from 0700 hours through 1/24/17 ending at 0556 hours

A total of 100.97 million gallons was blended over a period of 9 days. Rainfall recorded at the Richmond treatment plant totaled 11.65 inches which is 43% of the annual rainfall for the service area and the largest amount of rainfall recorded with our records going back to 2008.

Extra analyses were run as required by our permit, with no exceedances.

Due the unprecedented rainfall in January 2017 the West County Wastewater District's equalization basins overflowed to Wildcat Marsh from January 11, 2017 at 0700 to January 12, 2017 at 0115, for a duration of 42 hours. Approximately 9.07 million gallons overflowed to the marsh. Total rainfall measured at the WCWD Treatment Plant in January was 26.3 inches. This was one of the highest monthly totals ever recorded. All required reports were submitted to the RWQCB.

There were no Effluent NPDES Permit exceedances to report during the month.

I certify under penalty of law that this document and all attachments are prepared under my direction or supervision in accordance with a system designed to assure that qualified personnel properly gathered and submitted information. Based on my inquiry of the person or persons who managed the system, or those persons directly responsible for gathering the information, the information submitted is, to the best of my knowledge and belief, true, accurate, and complete. I am aware that there are significant penalties for submitting false information including the possibility of fine and imprisonment for knowing violations.

Respectfully,

Brian E. Hill
Interim General Manager
West County Wastewater District

cc: Vince Christian, San Francisco Bay Regional Water Quality Control Board;
Ryan Smith, City of Richmond
Aaron Winer, Veolia Water



March 29, 2017

Bruce Wolfe, Executive Officer
San Francisco Bay Regional Water Quality Control Board
1515 Clay Street, Suite 1400
Oakland, California 94612

RE: File No. 2213.1037 (RMD)tmb

Dear Mr. Wolfe,

Enclosed is the February 2017 Monthly Report.

On February 7th at 1030 hours the Richmond plants emergency generator transfer switch failed to reset to utility power after a 2.5 hour utility power outage. The age of the equipment was found to be the main cause of the issue. The plant is currently undergoing a 7 million dollar electrical power upgrade that is scheduled to be completed in early May of this year. That along with all major electrical equipment will be replaced.

There were three blending events at the Richmond WPCP in February covering the following time periods:

1. 2/7/17 from 0009 hours through 2/10/17 ending at 1610 hours
2. 2/17/17 from 1240 hours through 2/18/17 ending at 1330 hours
3. 2/20/17 from 0737 hours through 2/22/17 ending at 1426 hours

A total of 88.88 million gallons was blended over a period of 9 days.

Extra analyses were run as required by our permit, with no exceedances.

Due the continued unprecedented rainfall in February 2017 the West County Wastewater District's equalization basins overflowed to Wildcat Marsh from February 9, 2017 at 1630 to February 10, 2017 at 2130, for a duration of about 29 hours. Approximately 10.8 million gallons overflowed to the marsh. Total rainfall measured at the WCWD Treatment Plant in January was 26.6 inches followed by a February total of 12.7 inches. All required reports were submitted to the RWQCB.

There were no NPDES Permit effluent quality exceedances to report during the month.

I certify under penalty of law that this document and all attachments are prepared under my direction or supervision in accordance with a system designed to assure that qualified personnel properly gathered and submitted information. Based on my inquiry of the person or persons who managed the system, or those persons directly responsible for gathering the information, the information submitted is, to the best of my knowledge and belief, true, accurate, and complete. I am aware that there are significant penalties for submitting false information including the possibility of fine and imprisonment for knowing violations.

Respectfully,

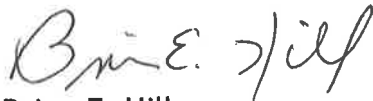

Brian E. Hill
Water Quality Manager
West County Agency

CC: Vince Christian, San Francisco Bay Regional Water Quality Control Board;
Ryan Smith, City of Richmond
Aaron Winer, Veolia Water



A Joint Powers Agency of West County Wastewater District
and City of Richmond Municipal Sewer District

April 28, 2017

Bruce Wolfe, Executive Officer
San Francisco Bay Regional Water Quality Control Board
1515 Clay Street, Suite 1400
Oakland, California 94612

RE: File No. 2213.1037 (RMD)tmb

Dear Mr. Wolfe,

Enclosed is the March 2017 Monthly Report.

There was one wet weather blending event at the Richmond WPCP in March which started at 1055 on 3/21/17 and ended at 1920 on the same day. The total volume blended was 1.832 million gallons and the event lasted 8.42 hours. Extra analyses were run as required by our permit, with no exceedances.

We had some collection problems in February when we first scheduled the Chronic Bioassay. We rescheduled it for March. Pacific Ecorisk could not get their organisms from their usual supplier and the ones they received failed in the control test that was run concurrently with ours. They were able to obtain new organisms in time to start a test the last week of March. Our samples were collected March 29 through April 4, so the test extended into next quarter. We have reported the results March 31, 2017, since this was the bioassay for the first quarter.

On March 5, 2017, the combined effluent (EFF-001) flow recorder malfunctioned and so there are no flow values for that location for that day.

There were no NPDES Permit exceedances to report during the month.

I certify under penalty of law that this document and all attachments are prepared under my direction or supervision in accordance with a system designed to assure that qualified personnel properly gathered and submitted information. Based on my inquiry of the person or persons who managed the system, or those persons directly responsible for gathering the information, the information submitted is, to the best of my knowledge and belief, true, accurate, and complete. I am aware that there are significant penalties for submitting false information including the possibility of fine and imprisonment for knowing violations.

Respectfully,

Brian E. Hill
Water Quality Manager
West County Wastewater District

cc: Vince Christian, San Francisco Bay Regional Water Quality Control Board;
Ryan Smith, City of Richmond
Aaron Winer, Veolia Water

WEST COUNTY AGENCY



A Joint Powers Agency of West County Wastewater District
and City of Richmond Municipal Sewer District

*Agenda Item No. 7. a.
Supporting Document - Attachment D
WCA Board Meeting - June 15, 2017
Page 1 of 1*

May 30, 2017

Bruce Wolfe, Executive Officer
San Francisco Bay Regional Water Quality Control Board
1515 Clay Street, Suite 1400
Oakland, California 94612

RE: File No. 2213.1037 (RMD)tmb

Dear Mr. Wolfe,

Enclosed is the April 2017 Monthly Report.

There were no NPDES Permit exceedances to report during the month.

I certify under penalty of law that this document and all attachments are prepared under my direction or supervision in accordance with a system designed to assure that qualified personnel properly gathered and submitted information. Based on my inquiry of the person or persons who managed the system, or those persons directly responsible for gathering the information, the information submitted is, to the best of my knowledge and belief, true, accurate, and complete. I am aware that there are significant penalties for submitting false information including the possibility of fine and imprisonment for knowing violations.

Respectfully,

Edward H. McCormick
Interim General Manager
West County Wastewater District

cc: Vince Christian, San Francisco Bay Regional Water Quality Control Board
Ryan Smith, City of Richmond
Aaron Winer, Veolia Water



Community Partner for Our Bay, Our Environment

March 31, 2017

Bruce Wolfe, Executive Officer
SF Bay Regional Water Quality Control Board
1515 Clay Street, Suite 1400
Oakland, CA 94612

RE: File No. 2213.1037 (RMD) tmb

Dear Mr. Wolfe:

Enclosed is the October 2016 Monthly Report for the West County Wastewater District (WCWD). This replaces the monthly report for October 2016 previously submitted for WCWD. The data is being resubmitted now because eSMR did not completely upload all the influent results for INF-003 last year.

There were no WCWD NPDES permit effluent quality exceedances to report during the month. Please refer to the original cover letter for other West County Agency report information.

I certify under penalty of law that this document and all attachments are prepared under my direction or supervision in accordance with a system designed to assure that qualified personnel properly gathered and submitted information. Based on my inquiry of the person or persons who managed the system, or those persons directly responsible for gathering the information, the information submitted is, to the best of my knowledge and belief, true, accurate, and complete. I am aware that there are significant penalties for submitting false information including the possibility of fine and imprisonment for knowing violations.

Respectfully,

Brian E. Hill
Water Quality Manager

BOARD MEMBERS

David Alvarado
Audrey L. Comeaux
Leonard R. McNeil
Sherry A. Stanley
Harry Wiener

BOARD ATTORNEY

Alfred A. Cabral

**INTERIM
GENERAL MANAGER**

Brian E. Hill

CC: Vince Christian, San Francisco Bay Regional Water Quality
Control Board



Community Partner for Our Bay, Our Environment

March 31, 2017

Bruce Wolfe, Executive Officer
SF Bay Regional Water Quality Control Board
1515 Clay Street, Suite 1400
Oakland, CA 94612

RE: File No. 2213.1037 (RMD) tmb

Dear Mr. Wolfe:

Enclosed is the December 2016 Monthly Report for the West County Wastewater District (WCWD). This replaces the monthly report for December 2016 previously submitted for WCWD. The data is being resubmitted now because eSMR did not completely upload all the influent results for INF-003 earlier this year.

There were no WCWD NPDES permit effluent quality exceedances to report during the month. Please refer to the original cover letter for other West County Agency report information.

I certify under penalty of law that this document and all attachments are prepared under my direction or supervision in accordance with a system designed to assure that qualified personnel properly gathered and submitted information. Based on my inquiry of the person or persons who managed the system, or those persons directly responsible for gathering the information, the information submitted is, to the best of my knowledge and belief, true, accurate, and complete. I am aware that there are significant penalties for submitting false information including the possibility of fine and imprisonment for knowing violations.

Respectfully,

Brian E. Hill
Water Quality Manager

BOARD MEMBERS

David Alvarado
Audrey L. Comeaux
Leonard R. McNeil
Sherry A. Stanley
Harry Wiener

BOARD ATTORNEY

Alfred A. Cabral

**INTERIM
GENERAL MANAGER**

Brian E. Hill

CC: Vince Christian, San Francisco Bay Regional Water Quality
Control Board

Return to Agenda

WEST COUNTY AGENCY



A Joint Powers Agency of West County Wastewater District
and City of Richmond Municipal Sewer District

TO: Honorable West County Agency Board of Directors
DATE: June 15, 2017
REPORT BY: Ed McCormick, Interim Agency Manager *LMC for EHS*
SUBMITTED BY: Maria L. Sena, WCWD Administration Supervisor
Ken Cook, WCWD Engineering Services Manager
SUBJECT: Report on Underwater Marine Outfall ATON Marker Inspection

RECOMMENDATION

Accept the inspection report and consider authorizing Agency Manager to enter into agreement with Global Diving and Salvage, Inc. for the Outfall Pipe repairs recommended as the result of this inspection.

FISCAL IMPACT

The total cost for the underwater West County Agency ATON Buoy Markers inspection is \$16,700 and is covered under the agreement with Global Diving & Salvage, Inc. The cost is shared between West County Wastewater District and the City of Richmond, 32% and 68% respectively. The recommended outfall pipe repairs is estimated to cost approximately \$38,230.

BACKGROUND AND DISCUSSION

The West County Agency (WCA) entered into a three year agreement with Global Diving & Salvage, Inc. on March 17, 2016. The scope of work includes the annual inspection of the WCA joint outfall and quarterly inspections and maintenance of the two ATON outfall marker buoys.

On April 5, 2017, Global Diving and Salvage, Inc. (GDS) performed a detailed inspection of the submerged sections of the marine outfall marker buoys. Attached is the detailed report of the inspection results and the repair recommendations to the outfall pipe from GDS.

Staff will be available to answer questions.

SUPPORTING DOCUMENTS

Attachment A: Global Diving & Salvage, Inc. Inspection Report and photos
Attachment B: Global Diving & Salvage, Inc. Inspection Invoice
Attachment C: Global Diving & Salvage, Inc. Proposal for Outfall Pipe Repair

BOARD MEMBERS: Jovanka Beckles - Audrey Comeaux - Eduardo Martinez - Leonard McNeil
ALTERNATE BOARD MEMBER: Jael Myrick, City of Richmond - Sherry Stanley, WCWD
BOARD ATTORNEY: Alfred Cabral **INTERIM AGENCY MANAGER:** Ed McCormick

Underwater ATON Marker Inspection

April 5, 2017

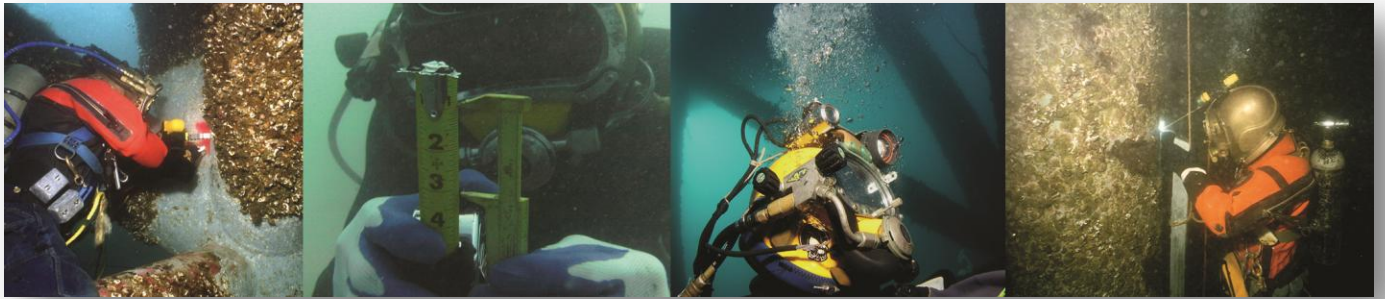

Prepared for:

West County Wastewater District

Submitted By:

Global Diving and Salvage, Inc.

1080 Nimitz Ave. Suite 440

Mare Island, Vallejo, CA 94592

INTRODUCTION

The marine outfall has two “tension moored” marker buoys that indicate the inshore of offshore location of the diffuser section. The markers, placed in service in the early 1990’s, have regular performance checks, inspections and maintenance performed on the topside flashing lights, radar beacon, storage batteries, and solar panels. In 2012, the corroded and damaged top sections of both marker markers were replaced.



Inshore Marker prior to replacement



Preparing to install the new top package in 2012

In 2016, Global recommended that a detailed inspection of the submerged sections of the markers be performed. The inspection would involve spot cleaning along the entire buoy structure below the water, with a focus on critical mechanical connections and appurtenances, particularly the clump weight pad eyes and shackles.

The inshore marker (WCA No. 2) was inspected June 30th, 2016. The offshore marker (WCA 1) was inspected on January 29th, 2016, and again on March 5th, 2017 when conditions provided more acceptable visibility for video documentation.

INSPECTION RESULTS

Per the inspection proposal scope, the mechanical connections of the submerged tension moored marker components were thoroughly cleaned of marine growth to allow an unobstructed view of the feature. These areas of highest concern were centered on connecting flanges, the buoyant float section, the adjustable pipe section, and the connection of the lower leg to the concrete “sinker” or clump weight. The straight pipe sections were spot cleaned in random locations to allow a representative evaluation of the less critical areas. The drawing (1993) on the following page shows the arrangement of the marker buoy components.

Float Section

The upper and lower flange connection hardware is in place and secure, however the flanges exhibit corrosion pitting and material loss, particularly on the flange reinforcing gussets connection.

The float section itself has several plugged ports through which high density foam was injected. The shell of the float section is in generally good condition, with no major damage observed in the cleaned areas.

The top and bottom ends of the float section have doubler plates welded in place to provide additional support for the flanges, and feature lifting eyes for installation and recovery. The welds appear to be in satisfactory condition.

Adjustable Pipe Section

The area below the float has an adjustable connection to allow the overall length to be shortened or lengthened during the field installation. The adjustment is created by inserting a smaller diameter, lower pipe section into a larger diameter upper pipe section. The larger diameter pipe section is slotted on opposing sides, and has a welded split clamp that can be drawn together with stainless steel draw bolts. On both markers the slot in the pipe between the draw flanges extends upward past the draw bolts. This extended slot is very uneven, with slot width varying by up to two inches. The initial impression was that this was a result of advanced corrosion, however it may also be a very rough flame cut performed in the field during installation to allow the pipe to be spread more easily at the adjustment clamp.

There are holes in the upper pipe section, and also at even intervals in the smaller diameter lower pipe section. When the smaller pipe is inserted into the larger pipe/clamp, and these holes align at the desired length, through bolts are inserted to positively pin the two pipe sections together. There are three of these through bolts installed in this manner, which appear to be in good shape on the exposed area. The possibility of wear or corrosion of the bolts on the inside of the connection should be considered.

The clamp "ears" have a 6 draw bolts installed and tight; 3 on either side. Although the clamp ears are touching with no gap between them, there is an annular space remaining between the upper and lower pipe sections.

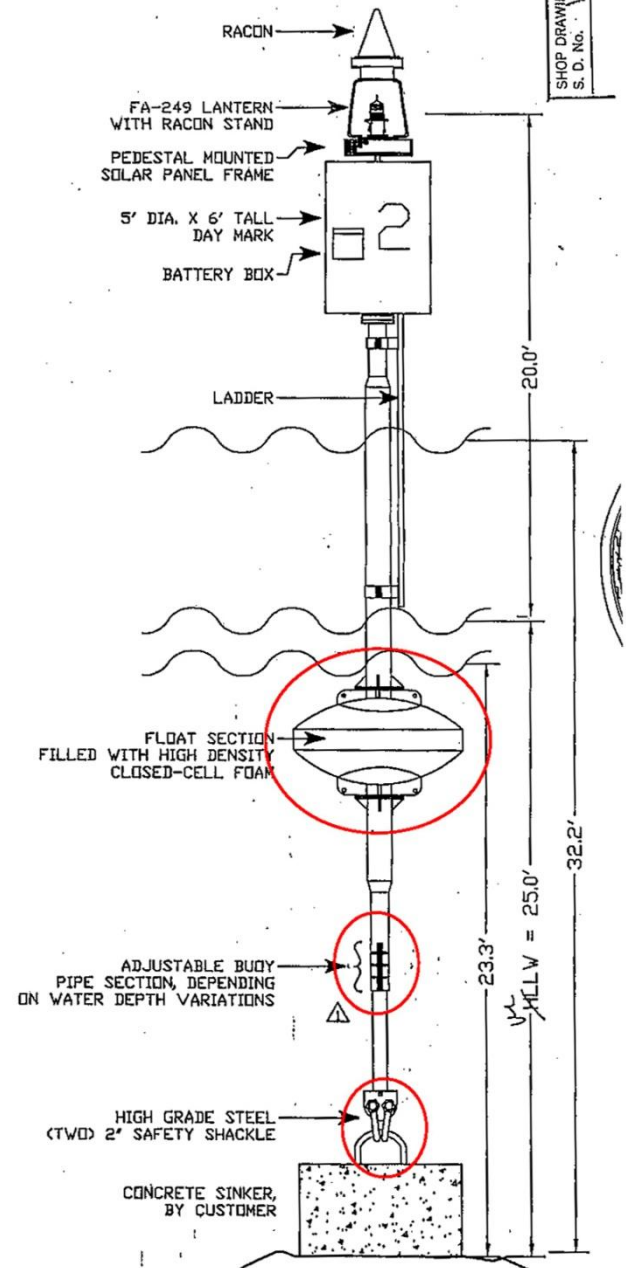

1993 Shop Drawing of Tension Moored buoy arrangement

Connection to Concrete Sinker

This connection provides the most immediate concern, as there is significant wearing on both the 2" shackles and the 3" lifting eye cast into the concrete clump weight, or sinker. This wear is common to both markers, and is estimated to have reduced the original cross section of the shackles and sinker attachment point by 40-60%.

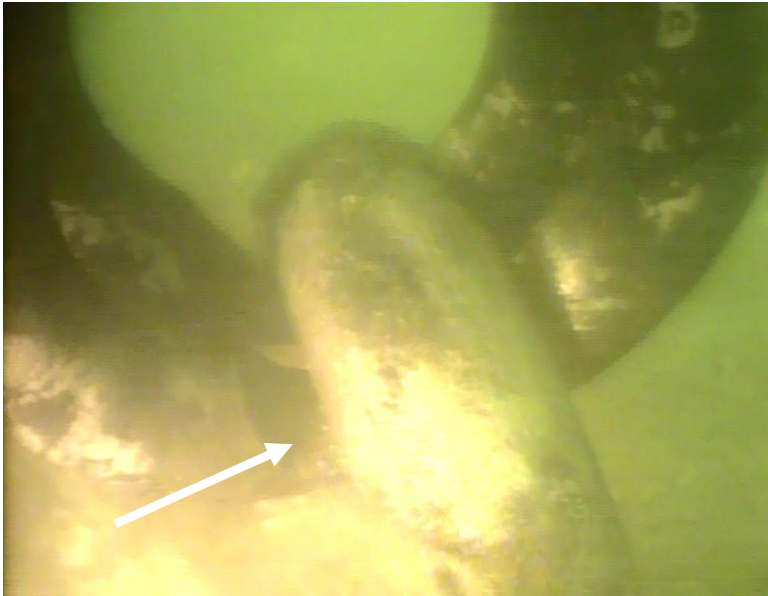

Image showing typical wear on two inch shackles – WCA-2 (Inshore) Marker



View showing cross section loss on 3" lifting eye

Recommendations

The marker buoys have been in place for over 20 years in an exposed location. Although the top sections have been replaced, consideration should now be given to replacing the lower sections. The general corrosion occurring throughout the submerged areas (particularly on the flange gussets at the float section connection) and the loss of material at the critical connection points to the concrete sinker are concerning. It cannot be reliably predicted when a failure might occur, but the potential result of a marker released from its mooring and drifting away in a semi-submerged attitude is an unattractive scenario to consider.

Anticipating that the District will be interested in further details for planning or budgeting purposes, Global has had preliminary discussions with the original buoy manufacturer for information regarding their estimated fabrication costs.

Respectfully Submitted,

Project Manager
GLOBAL DIVING & SALVAGE



Job Number: 108233-001
P.O. Number: AGREEMENT
P.O. Date: 4/6/2017
Ship Date: 4/6/2017
Sales Person: KEVIN PEHLE

Invoice No: IN-130507
Invoice Date: 4/7/2017
Due Date: 5/7/2017
Payment Terms: NET 30
Customer No.: C101924
Contact:
Customer Phone: 510-222-6700
Customer Fax: 510-222-3277

Bill To:
 WEST COUNTY WASTEWATER DISTRICT
 2910 HILLTOP DRIVE
 RICHMOND, CA 94806

Job Site:
 West County Outfall & Buoy
 3 Year Agreement (Exp 2019)
 E.J. Shalaby
 Richmond, CA

DATE	ITEM/DESCRIPTION	U/M	QUANTITY	UNIT PRICE	TOTAL PRICE
4/6/2017	Underwater inspection of subsurface ATON components w/written report and video.	Days	2.00	8,350.00	16,700.00
		Subtotal:	4/6/2017		16,700.00

Thank you for your business!

Amount Subject to Sales Tax	Amount Exempt from Sales Tax
0.00	16700.00

Remit To:
3840 West Marginal Way SW
ATTN: Accounts Receivable
Seattle, WA 98106

Subtotal:	16,700.00
Less Retention:	0.00
Total Sales Tax:	0.00
Total:	16,700.00





May 26, 2016

West County Wastewater District
2910 Hilltop Drive
Richmond, CA 94806

Attn: E.J. Shalaby
District Manger

Re: Proposal for Outfall Pipe Repair and Additional Work

Scope of Work

Global Diving and Salvage, Inc. (Global) will provide labor, equipment on a daily rate basis to carry out the following work not included in the current 3 year inspection and maintenance work agreement:

Repair of Spalled Concrete and Exposed Rebar – Diffuser 133 and 137

Recommendations were provided to WCWD (see *Marine Outfall Diffuser Section Internal Dredging and Inspection* report dated 2/3/2016) for several repair options. The District has directed that the option to clean and repair concrete spalling and exposed rebar with underwater epoxy and/or hand packing hydraulic cement is desired. The work will take place both inside the pipeline and externally in the immediate area of the each diffuser. The area will be cleaned, with damaged rebar cut back (if necessary) to sound concrete, after which epoxy and/ or hydraulic cement will be applied to prevent further corrosion.

The basic equipment and labor cost for internal sediment removal and inspection performed under the existing work agreement will apply to the repair effort, with the addition of consumed materials.

Qty	Description	Daily Rate	Total
3	Days -Daily Rate for 5 Man Dive Team, Equipment, and 43' Dive Support Vessel	\$12,460	\$37,380
1	Estimated Consumables (Underway Epoxy/Hydraulic Cement)	\$850	\$850
Total Estimated Repair Cost			\$38,230

The repair work duration is estimated at 2-3 days, and will follow the annual internal inspection and dredging of the final 100 feet of the diffuser section work performed under the existing service contract.

1080 Nimitz Ave, Ste 440 • Mare Island • Vallejo, CA 94592 • www.gdiving.com • 24hr: (707) 561-6810 • Fax: (707) 561-6811



Inspection of Outfall Marker Buoys

An underwater inspection of the offshore and inshore marker buoys will be performed to determine the structural integrity of major subsurface components. The submerged areas include several important connections shown in the annotated shop drawing at right, which are covered in heavy marine growth.

The float section connections, adjustable buoy pipe section, and hardware connecting the buoy to the concrete sinker will be cleaned and video inspected for damage, corrosion, or any other deficiency. Spot cleaning and inspection will be performed along the remaining pipe lengths.

The inspection is estimated to require 1-2 days to complete, at the following daily rate:

Qty	Description	Daily Rate	Total
2	Days - Daily Rate for 3 Man Dive Team, Equipment, and 43' Dive Support Vessel	\$8,350	\$16,700

Pricing Notes

- The outfall work takes place in an area of high currents, and work will be scheduled for slack water periods. The buoy inspection will take place at the earliest opportunity. The repair activities will be scheduled to immediately follow the annual inspection and maintenance work, normally performed in the late summer/early fall.
- The total costs reflect the maximum estimated duration for each activity. Global will make every effort to complete the work as efficiently as possible, and pass along any savings to the District resulting from an earlier completion.

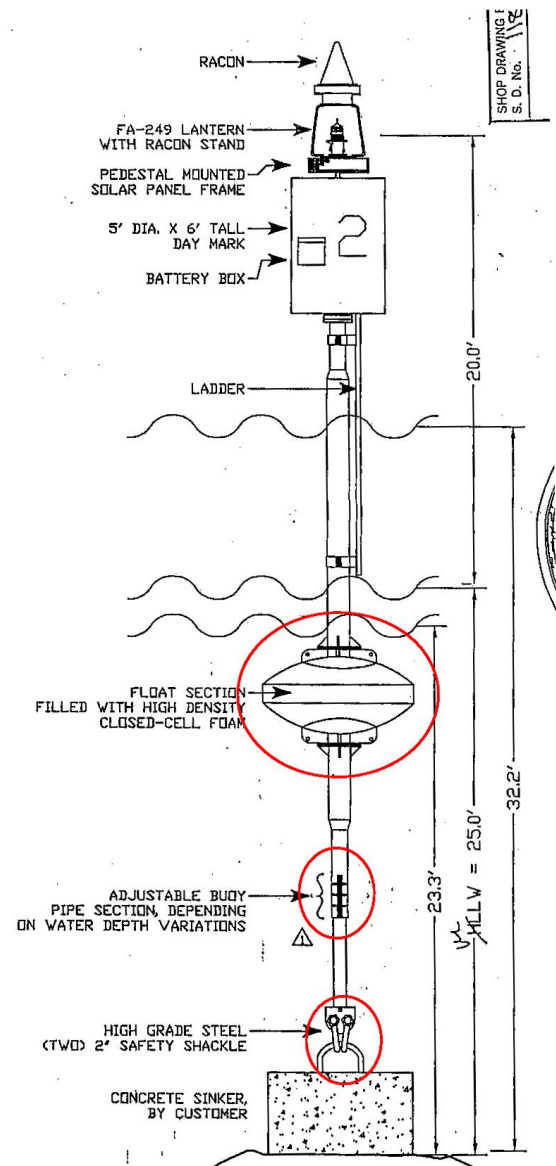

Manufacturer Shop Drawing - 1993

Return to Agenda

Respectfully submitted,

Rick Heaslet
Project Manager

**LAW OFFICES
PELLETREAU, ALDERSON & CABRAL
P.O. BOX 1000
GRASS VALLEY, CA 95945
TELEPHONE: (510) 262-2100
FACSIMILE: (530) 478-0368**

Agenda Item No. 8. e.

APRIL 1, 2017

WEST COUNTY AGENCY
2910 HILLTOP DRIVE
RICHMOND, CA 94806

RE: STATEMENT FOR GENERAL SERVICES
OUR FILE: 2005.1

PROFESSIONAL SERVICES

<u>DATE</u>	<u>DESCRIPTION</u>	<u>HOURS</u>	<u>AMOUNT</u>
03/08/17	Receive and review e-mails regarding meeting	0.25	56.25
03/15/17	Receive and review agenda and supporting materials and begin preparation for meeting	0.50	112.50
03/16/17	Attend meeting	<u>1.50</u>	<u>337.50</u>
	TOTAL PROFESSIONAL SERVICES	2.25	\$ 506.25
	TOTAL NEW CHARGES		\$ 506.25

SUMMARY OF ACCOUNT

BALANCE FORWARD	\$ 0.00
TOTAL NEW CHARGES	506.25
PAYMENTS AND CREDITS	<u>0.00</u>
TOTAL BALANCE DUE	\$ 506.25

LAW OFFICES
PELLETREAU, ALDERSON & CABRAL
P.O. BOX 1000
GRASS VALLEY, CA 95945
TELEPHONE: (510) 262-2100
FACSIMILE: (530) 478-0368

Agenda Item No. 8. e.
WCA Board Meeting - June 15, 2017
Page 2 of 3

MAY 1, 2017

WEST COUNTY AGENCY
2910 HILLTOP DRIVE
RICHMOND, CA 94806

RE: STATEMENT FOR GENERAL SERVICES
OUR FILE: 2005.1

TOTAL NEW CHARGES	\$ 0.00
PREVIOUS BALANCE DUE	\$ 506.25
PAYMENTS AND CREDITS	
04/17/17 Payment Received - Thank You	<u>-506.25</u>
TOTAL PAYMENTS AND CREDITS	\$ -506.25

SUMMARY OF ACCOUNT

BALANCE FORWARD	\$ 506.25
TOTAL NEW CHARGES	0.00
PAYMENTS AND CREDITS	<u>-506.25</u>
TOTAL BALANCE DUE	\$ 0.00

LAW OFFICES
PELLETREAU, ALDERSON & CABRAL
P.O. BOX 1000
GRASS VALLEY, CA 95945
TELEPHONE: (510) 262-2100
FACSIMILE: (530) 478-0368

Agenda Item No. 8. e.
WCA Board Meeting - June 15, 2017
Page 3 of 3

JUNE 1, 2017

WEST COUNTY AGENCY
2910 HILLTOP DRIVE
RICHMOND, CA 94806

RE: STATEMENT FOR GENERAL SERVICES
OUR FILE: 2005.1

TOTAL NEW CHARGES

\$ 0.00

SUMMARY OF ACCOUNT

BALANCE FORWARD	\$ 0.00
TOTAL NEW CHARGES	0.00
PAYMENTS AND CREDITS	<u>0.00</u>
TOTAL BALANCE DUE	\$ 0.00

Return to Agenda

**West County Agency
Budget to Actuals Report
Fiscal Year 2017 Period Ending May 2017**

Agenda Item No. 9. a.

<u>WEST COUNTY AGENCY</u>	<u>FY 2016</u> <u>Actual</u>	<u>FY 2017</u> <u>Adopted</u>	<u>Actuals</u> <u>through May</u>	<u>Variance</u>	<u>Percent</u> <u>Collected/</u> <u>Spent</u>
<u>Revenue</u>					
Member Payment WCWD	\$ 148,541	\$ 153,360	\$ 137,205	\$ 16,155	89%
Member Payment City of Richmond	\$ 198,964	\$ 168,840	\$ 157,891	\$ 10,949	94%
Misc. Operating Revenue	\$ 496	\$ -	\$ -	\$ -	
<u>Expenses</u>					
Director Stipends	\$ 4,776	\$ 5,200	\$ 2,654	\$ 2,547	51%
Social Security Contributions	\$ 296	\$ 400	\$ 165	\$ 236	41%
Medicare Contributions	\$ 69	\$ 100	\$ 39	\$ 62	39%
General Counsel	\$ 3,881	\$ 4,000	\$ 1,406	\$ 2,594	35%
Banking services	\$ 1,062	\$ 1,000	\$ 744	\$ 256	74%
Outside Audit	\$ 5,500	\$ 5,500	\$ 5,500	\$ -	100%
Misc. Professional Services	\$ 60,999	\$ 60,000	\$ 30,418	\$ 29,583	51%
Professional Dues and Fee	\$ 23,271	\$ 24,000	\$ 23,428	\$ 572	98%
Insurance Premiums	\$ 2,573	\$ 3,000	\$ 1,987	\$ 1,013	66%
Printing and Binding		\$ 100	\$ -	\$ 100	0%
Gas/Electricity	\$ 486	\$ 1,000	\$ 628	\$ 372	63%
Building & Structures Maintenance	\$ 66,960	\$ 40,000	\$ 61,973	\$ (21,973)	155%
City Permit	\$ 1,253	\$ 1,500	\$ -	\$ 1,500	0%
State Permit	\$ 125,896	\$ 132,000	\$ 115,973	\$ 16,027	88%
Misc. Permit	\$ 41,522	\$ 44,000	\$ 56,697	\$ (12,697)	129%
Clothing	\$ 87	\$ 200	\$ 167	\$ 33	84%
Meeting Supplies	\$ -	\$ 100	\$ 27	\$ 73	27%
Misc. Supplies	\$ 118	\$ 100	\$ -	\$ 100	0%
Bad Debt Expense	\$ (1,239)	\$ -	\$ -	\$ -	
Total Revenue	\$ 348,001	\$ 322,200	\$ 295,095	\$ 27,105	92%
Total Expense	\$ 337,510	\$ 322,200	\$ 301,804	\$ 20,396	94%
Net Total	\$ 10,491	\$ -	\$ (6,709)	\$ 6,709	-2%

West County Agency
 Payment Dates: 3/1/17 - 5/31/17

<u>Payment Number</u>	<u>Payment Date</u>	<u>Vendor Name</u>	<u>Description (Payable)</u>	<u>Amount</u>
Fund: 800 - WEST COUNTY AGENCY FUND				
7378	03/10/2017	CORRPRO COMPANIES, INC.	Service- Eng. Svcs- CP7	\$ 900.00
7390	05/17/2017	CORRPRO COMPANIES, INC.	Bid Phase Support Cathodic Protection CP-7	\$ 1,600.00
7384	04/07/2017	GLOBAL DIVING & SALVAGE INC.	Jan-Mar FY17 Quarterly ATON Maintenance	\$ 4,150.00
			Underwater Inspection of Subsurface ATON	\$ 16,700.00
			Componets, Written Report and Video 2 Days @	
7391	05/17/2017	GLOBAL DIVING & SALVAGE INC.	8,350	
7381	03/31/2017	LARRY WALKER ASSOCIATES, INC.	WCA NPDES Permit Assistance - January 2017	\$ 852.00
7379	03/10/2017	PACIFIC GAS & ELECTRIC	WCA Cathodic Electric - 3684901439-8	\$ 70.32
7385	04/07/2017	PACIFIC GAS & ELECTRIC	WCA Cathodic Electric - 4779739496-3	\$ 17.40
7388	04/28/2017	PACIFIC GAS & ELECTRIC	WCA Cathodic Electric - 3684901439-8	\$ 18.42
7392	05/17/2017	PACIFIC GAS & ELECTRIC	WCA Cathodic Electric - 2354684571-2	\$ 47.12
7386	04/07/2017	PELLETREAU, ALDERSON & CABRAL	March 2017 WCA Legal Services	\$ 506.25
7383	03/31/2017	WEST COUNTY WASTEWATER DISTRICT	WCWD Labor Charges 01/17 AH	\$ 463.54
7387	04/07/2017	WEST COUNTY WASTEWATER DISTRICT	WCA Billings From WCWD February 2017	\$ 2,985.93
7389	04/28/2017	WEST COUNTY WASTEWATER DISTRICT	WCA Billings From WCWD March 2017	\$ 1,946.87
			WEST COUNTY AGENCY TOTAL	\$ 30,257.85

Return to Agenda

WEST COUNTY AGENCY



A Joint Powers Agency of West County Wastewater District
and City of Richmond Municipal Sewer District

TO: Honorable Board of Directors
West County Agency

DATE: June 15, 2017

REPORT BY: Ed McCormick, Interim Agency Manager *LMZ for EHS*

SUBMITTED BY: Lisa K. Malek-Zadeh, Business Services Manager

SUBJECT: FY 2018 Proposed Budget

RECOMMENDATION

Staff recommends that the Board review and adopt the proposed West County Agency (Agency) Budget for Fiscal Year 2018.

FISCAL IMPACT

The total FY 2018 Proposed Budget is \$386,500. The City of Richmond's share is \$206,570 and West County Wastewater District's (WCWD) share is \$179,930 per the member allocation's specified by the Joint Exercise of Powers Agreement.

BACKGROUND AND DISCUSSION

Fiscal Year 2017 Budget Update

The Agency adopted the FY 2017 Budget on June 16, 2016. Staff used April 2017 Year-To- Date Actual results and estimated costs for the remainder of the fiscal year to forecast FY 2017 results. No adjustment is proposed for the current FY 2017 budget. Budget items that are projected to exceed the Adopted Budget are offset by budget items that are projected to be underspent. As a result, the adopted Budget is proposed to remain unchanged and no adjustments are recommended.

Property related expenses are shared 68%/32% City of Richmond/WCWD based upon the relative property contribution of each party. Other expenses are shared 50%/50%. As a result of Projected versus Budgeted expenses, a cost increase of \$9,010 is projected for WCWD, partially offset by a cost decrease of \$710 for the City of Richmond.

BOARD MEMBERS: Jovanka Beckles - Audrey Comeaux - Eduardo Martinez - Leonard McNeil
ALTERNATE BOARD MEMBER: Jael Myrick, City of Richmond - Sherry Stanley, WCWD
BOARD ATTORNEY: Alfred Cabral **INTERIM AGENCY MANAGER:** Ed McCormick

FY 2018 Proposed Budget

The proposed FY 2018 budget of \$386,500 represents a \$64,300 increase (+20%) compared to the FY 2017 Adopted Budget of \$322,100.

Proposed Changes from Prior Year Budget:

1. Increase in Buildings and Structures Maintenance from \$40,000 to \$71,000. This is for the vendor Corropro continuing work on the Cathodic Protection project.
2. Increase in State and Regional Monitoring Program annual permits from \$10,000 to \$30,000 for the San Francisco Estuary Regional Monitoring Program. Larry Walker Associates notified the Board at the 3/16/17 meeting that this permit would double or triple.
3. Increase in Regional Monitoring Program participant fees from \$20,000 to \$34,000, based upon actual FY 2017 costs.

WCA invoices the City of Richmond for its share of annual budgeted expenditures while WCWD is invoiced and paid on a monthly basis for reimbursement of its share of actual expenditures. If there is a remaining balance of the amount paid by the City of Richmond after all expenses are recorded for the fiscal year and, these funds are applied to the next fiscal year's expenses. Should there be a balance owed, the Agency will bill the City of Richmond at the close of the fiscal year.

SUPPORTING DOCUMENTS

Attachment A: Proposed Budget Fiscal Year 2018

Attachment B: Resolution Adopting Fiscal Year 2018 Budget

West County Agency
 FY 2018 Proposed Budget

	FY 2015 Actual	FY 2016 Actual	FY 2017 Adopted	FY 2017 Projected	Change from FY 2017 Adopted to FY 2017 Projected	FY 2018 Proposed	Cost Allocation FY 2017 Projected		Cost Allocation FY 2018 Proposed		Cost Allocation Change from FY 2017 Adopted to FY 2018 Proposed	
							City of Richmond	WCWD	City of Richmond	WCWD	City of Richmond	WCWD
REVENUES												
City of Richmond	\$ 125,326	\$ 198,964	\$ 168,840	\$ 169,550	710	\$ 206,570	169,550		206,570		(37,020)	
West County Wastewater	99,545	148,541	153,360	144,350	(9,010)	179,930		144,350		179,930		(35,580)
Miscellaneous Revenue		496	-	-		-						
Revenues	\$ 224,871	\$ 348,001	\$ 322,200	\$ 313,900	\$ (8,300)	\$ 386,500	\$ 169,550	\$ 144,350	\$ 206,570	\$ 179,930	\$ (37,020)	\$ (35,580)
EXPENSES												
Director Compensation	4,246	4,776	5,200	3,600	(1,600)	4,300	50% 1,800	50% 1,800	50% 2,150	50% 2,150	(350)	(350)
Employee Benefits		365	500	300	(200)	400	50% 150	50% 150	50% 200	50% 200	(50)	(50)
General Counsel	2,081	3,881	4,000	2,000	(2,000)	4,000	50% 1,000	50% 1,000	50% 2,000	50% 2,000	(1,000)	(1,000)
Banking Fees	1,007	1,062	1,000	1,000	-	1,200	50% 500	50% 500	50% 600	50% 600	(100)	(100)
Outside Audit	5,500	5,500	5,500	5,500	-	5,500	50% 2,750	50% 2,750	50% 2,750	50% 2,750	-	-
Misc. Professional Services	9,757	60,999	60,000	34,000	(26,000)	64,000	50% 17,000	50% 17,000	50% 32,000	50% 32,000	(15,000)	(15,000)
Professional Dues	28,044	23,271	24,000	23,500	(500)	24,000	50% 11,750	50% 11,750	50% 12,000	50% 12,000	(250)	(250)
Registration Fees					-		100% -	0% -	100% -	0% -	-	-
Insurance	2,167	2,573	3,000	2,000	(1,000)	3,000	68% 1,360	32% 640	68% 2,040	32% 960	(680)	(320)
Postage					-		50% -	50% -	50% -	50% -	-	-
Printing			100	100	-	100	50% 50	50% 50	50% 50	50% 50	-	-
Electricity		486	1,000	700	(300)	1,000	50% 350	50% 350	50% 500	50% 500	(150)	(150)
Misc. Other Services					-		50% -	50% -	50% -	50% -	-	-
Travel					-		100% -	0% -	100% -	0% -	-	-
Per Diem					-		100% -	0% -	100% -	0% -	-	-
Lodging					-		100% -	0% -	100% -	0% -	-	-
Mileage					-		50% -	50% -	50% -	50% -	-	-
Buildings & Structures Maint.	16,600	66,960	40,000	68,000	28,000	71,000	68% 46,240	32% 21,760	68% 48,280	32% 22,720	(2,040)	(960)
Misc. Government Payments					-		68% -	32% -	68% -	32% -	-	-
City Permit		1,253	1,500		(1,500)	1,500	50% -	50% -	50% 750	50% 750	(750)	(750)
State Permit	112,582	125,896	132,000	116,000	(16,000)	128,000	50% 58,000	50% 58,000	50% 64,000	50% 64,000	(6,000)	(6,000)
Misc. Permit	32,148	41,522	44,000	56,900	12,900	78,000	50% 28,450	50% 28,450	50% 39,000	50% 39,000	(10,550)	(10,550)
Clothing	303	87	200	200	-	300	50% 100	50% 100	50% 150	50% 150	(50)	(50)
Meeting Supplies		118	200	100	(100)	200	50% 50	50% 50	50% 100	50% 100	(50)	(50)
Bad Debt Expense	6,836	(1,239)										
Expenses	221,271	337,510	322,200	313,900	(8,300)	386,500	169,550	144,350	206,570	179,930	(37,020)	(35,580)
NET SURPLUS/(DEFICIT)	\$ 3,600	\$ 10,491	\$ -	\$ (0)	\$ (0)	\$ (0)	(0)	(0)	(0)	(0)	0	0

**BOARD OF DIRECTORS OF THE WEST COUNTY AGENCY
COUNTY OF CONTRA COSTA, CALIFORNIA**

RESOLUTION NO. WCA 17-00__

**ADOPTING THE WEST COUNTY AGENCY BUDGET FOR FISCAL YEAR 2018 AND
AUTHORIZING THE AGENCY MANAGER TO EXPEND BUDGETED FUNDS**

The Board of Directors finds that:

Revenue for the West County Agency is derived solely from the reimbursement of expenses by the participating agencies and must be sufficient to cover the actual expenditures.

The Agency Manager needs the ability to expend budgeted funds to conduct the day-to-day business of the Agency.

The Board of Directors of the West County Agency adopts the West County Agency proposed Budget for Fiscal Year 2018, as attached to this Resolution, and authorizes the Agency Manager to expend budgeted funds in amounts up to the amounts reflected in the adopted budget without further Board action.

* * *

I HEREBY CERTIFY that the foregoing resolution was duly and regularly adopted by the Board of the West County Agency, Contra Costa County, California, at a meeting thereof held on the 15th day of June 2017, by the following vote:

AYES:

NOES:

ABSENT:

Chair of the Board
West County Agency
Contra Costa County, California

Return to Agenda